



东莞市凡睿电子科技有限公司

DONG GUAN FAN RUI ELECTRONICS&TECHNOLOGY CO.,LTD.

TEL: (0769) 81805438/86866001 13751429385 FAX (0769) 82991458 E-mail: fanrui@dgfarui.com

网址: <http://www.dgfarui.com>

地址: 东莞市茶山镇京山第三工业区

旋转式电位器规格书 Rotary potentiometer specification	核准 Approved	审核 Q.I.Department	经办者 Design Dept.
	刘建国	莫勤	王芳
适用机种: FR3590S Applicable Models : FR3590S			

Electrical Characteristics 电气特性

Range of nominal resistance 标称阻值范围	100 Ω - 100K Ω
Resistance tolerance 阻值允许偏差	<input checked="" type="checkbox"/> ±5% <input type="checkbox"/> ±10% <input type="checkbox"/> ±20%
Terminal resistance 终端电阻	≤ 1% 或 10Ω
Contact resistance variation 接触电阻变化	CRV ≤ 1%
Insulation resistance 绝缘电阻	R1 ≥ 1G Ω (100V DC)
Withstand voltage 耐电压	600V AC
Effective electrical travel 有效行程	> 总机械行程的 70% > 70% of Total mechanical travel

Environmental characteristics 环境特性

Rated Power (160V _{maz}) 额定功率	2W@70℃, 0W@125℃
Temperature range 温度范围	-55℃ - +125℃
TCR 温度系数	± 100ppm/℃
Collision 碰撞	1000m/s ² , 16ms, 1000 次 ΔR ≤ ± 2%R
Temperature cycle 温度循环	-55℃, 30 分钟, +100℃, 30min
3cycle 循环 3 次	ΔR ≤ ± 5%R, Δ(Uab/Uac) ≤ 10%
Electrical load at 85℃ 85℃ 电负荷	0.5W _m , ΔR ≤ ± 10%R, Δ(Uab/Uac) ≤ 10%
Constant damp-heat 恒定湿热	40 ± 2℃, 87-92%RH, H96h ΔR ≤ ± 5%R, R10 ≥ 10M Ω

Mechanical Characteristics 机械特性

Total mechanical rotation angle 总机械旋转角度	≥ 3600° ^{+10°} _{-0°}
Starting torque 启动力矩	≤ 35mN.m
Mark 标志	Type, nominal resistance 阻值代码、标称阻值
	Resistance tolerance 阻值允许偏差



东莞市凡睿电子科技有限公司

DONG GUAN FAN RUI ELECTRONICS&TECHNOLOGY CO.,LTD.

TEL: (0769) 81805438/86866001 13751429385 FAX (0769) 82991458 E-mail: fanrui@dgfarui.com

网址: http://www. dgfarui. com

地址: 东莞市茶山镇京山第三工业区

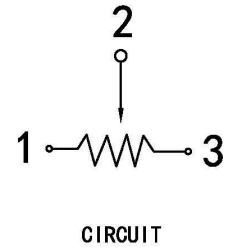
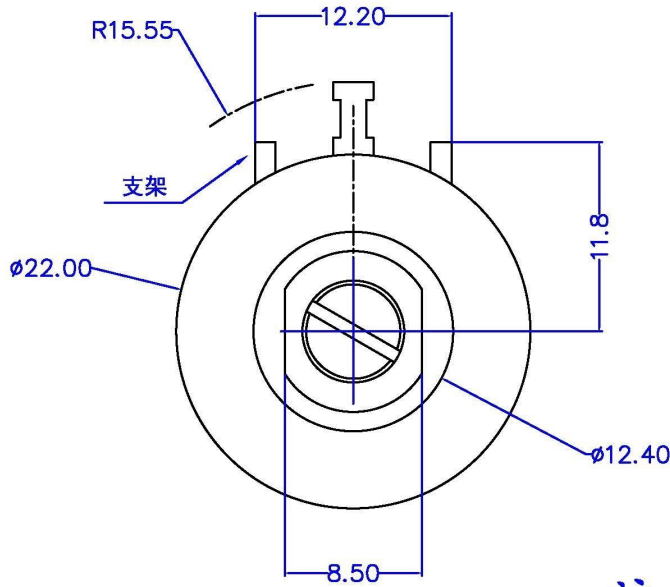
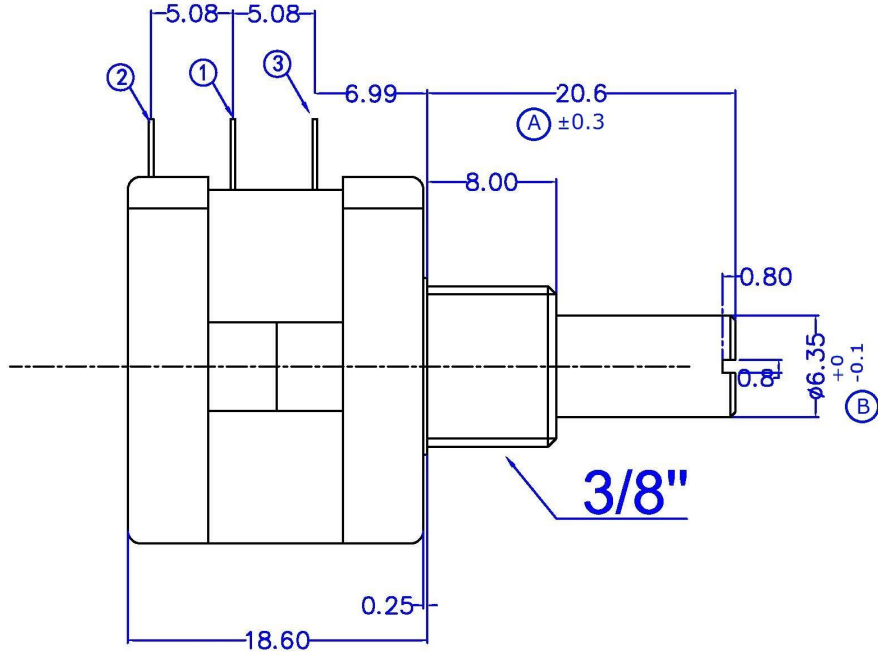

注：特殊要求产品寿命可定制20万次

						东莞市凡睿电子科技有限公司 DONG GUAN FAN RUI ELECTRONICS&TECHNOLOGY CO.,LTD.	
MTL		SPEC		DISPOSAL			
△				UNIT	SCALE	TITLE	
△				MM	2 / 1	FR3590S Series	
△				DRAWN	DESIGN	CHECK	APPROVAL
△							
△							
DEVISION	DATE	DESIGN				DWG NO.	
						DWG NAME	
						FR3590S-2-B103	



东莞市凡睿电子科技有限公司

DONG GUAN FAN RUI ELECTRONICS & TECHNOLOGY CO., LTD.

TEL: (0769) 81805438 / 86866001 13751429385 FAX (0769) 82991458 E-mail: fanrui@dgfarui.com

网址: <http://www.dgfarui.com>

地址: 东莞市茶山镇京山第三工业区

电位器曲线图

TAPERS B SERIES

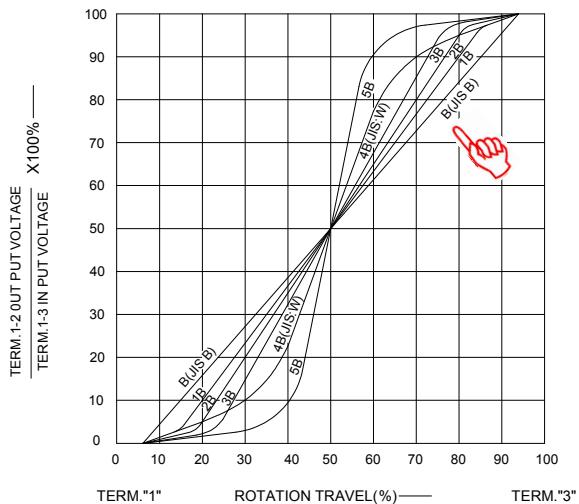

TAPERS B WITH 50% TAP

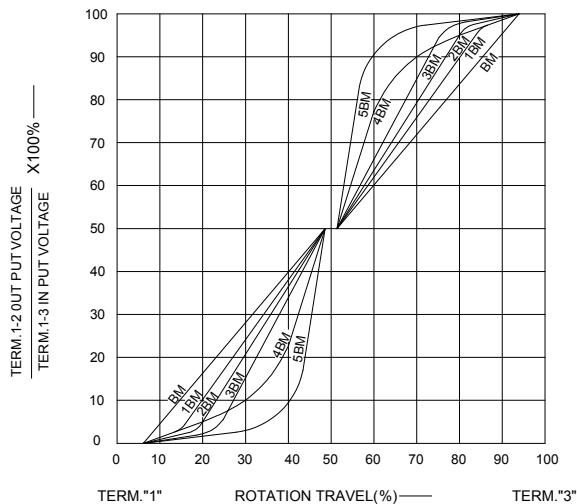

TAPERS A SERIES

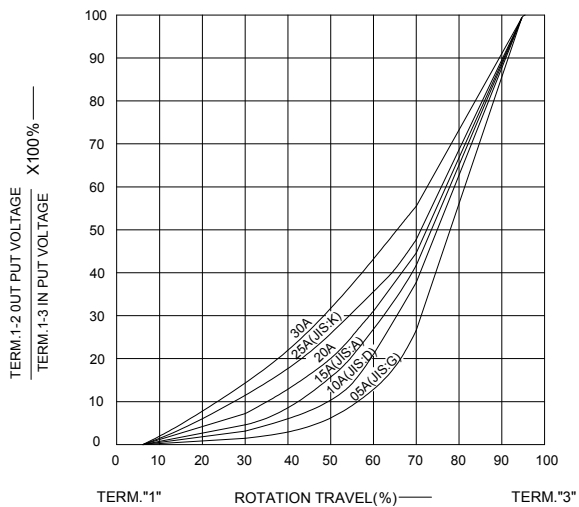

TAPERS A & C WITH 50% TAP

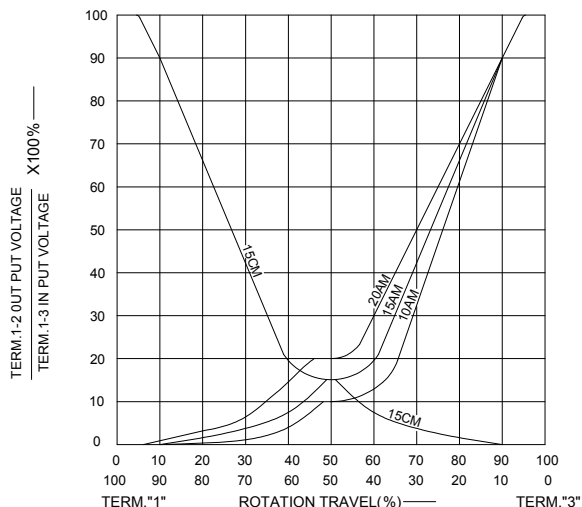

TAPERS C SERIES

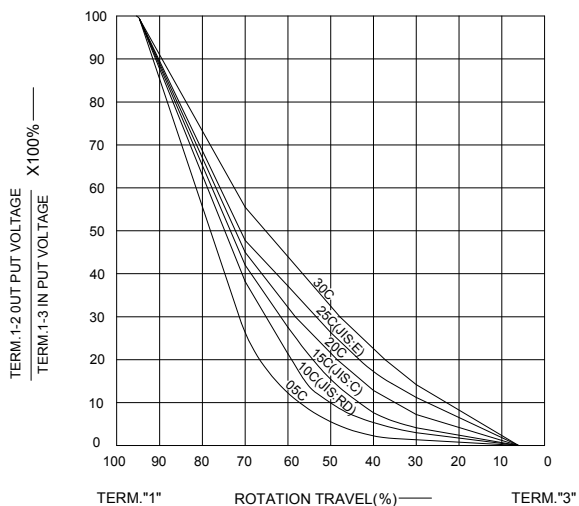

TAPERS M & N

